



# HF VALVES

## introduction

**PETROLVALVES** is a leading manufacturer of valves for the oil and gas industry. Formed in 1956, **PETROLVALVES** has grown to a company with sales, services and manufacturing facilities throughout the world with direct presence in the United States, Norway, United Kingdom, Italy, Singapore and Australia.

**PETROLVALVES** began producing specialty valves destined for the HF Alkylation industry and for the processing of Hydrofluoric Acid in 1958. The engineering, design, production, manufacturing and quality control departments have worked, in conjunction with the industries innovators and technology licensors, in a concerted effort to continuously improve the performance and reliability of our HF Valves. This evolution has been achieved by improving design features and machining standards while upgrading the selection of material utilized to meet or exceed applicable codes (API and ANSI) and customer's requirements.

This, combined with an in-line quality control system, has resulted in **PETROLVALVES** being the leading supplier of valves for HF application worldwide.

**PETROLVALVES** is a UOP Honeywell and Phillips approved supplier for HF valves. However, now that UOP has acquired Phillips HF Technology and intends to consolidate the technology, we prominently feature the UOP standards in our catalog. Please be advised that **PETROLVALVES** continues to supply a complete range of Phillips valves and has worldwide capability to perform full valve reconditioning during HF unit shutdown.

**PETROLVALVES** extends a full guarantee on the performance of its valves for Alkylation and HF acid production and processing.

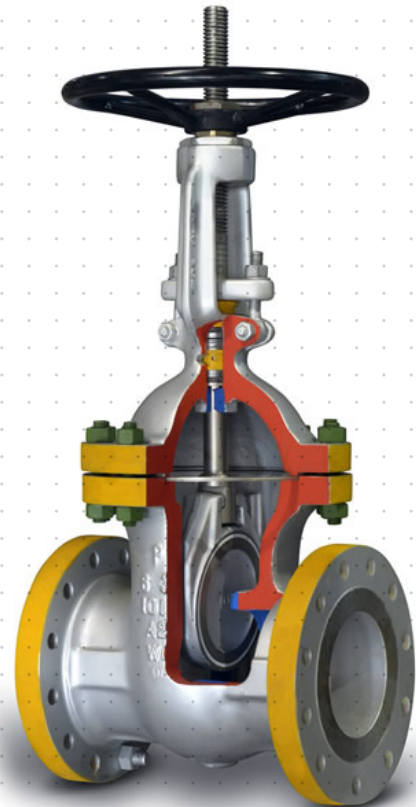

## what is ALKYLATION?

Definition: «alkylation» is a chemical process used to produce higher octane Alkylates by adding low-molecular-weight alkenes to isobutane. During the process, either sulfuric acid or hydrofluoric acid (H-F) is used as a catalyst.

Alkylation is a process which is performed in refineries by using extremely acid fluids; due to this, corrosion of surfaces is an important consideration for valves designed for alkylation plants.

For most severe applications, alkylation valves have Monel body and trim; for simpler and less critical environments, Monel trims are used in carbon steel bodies, built with an appropriate corrosion allowance.

01

## uop HONEYWELL

UOP Honeywell is a global leader in alkylation field. From a few decades ago, UOP became a key player in the business, by issuing specifications for testing and design of alkylation valves. UOP specs are now recognized worldwide as a standard for alkylation process.

Valve suppliers that are interested in alkylation business are therefore required to be “UOP approved” by producing valves in compliance with latest revision of UOP specifications.

**PETROLVALVES** is a UOP Approved supplier with a complete Gate, Globe and Check valves product line.

## valve design KEY POINTS

By working with end users, the technology licensor, and following API and ANSI standards, **PETROLVALVES** has enhanced the HF valve design in the following ways:

- ▶ renewable seat rings threaded into monel overlaid pockets with nickel butter layer - simplifies maintenance.
- ▶ renewable seal welded seats options: proprietary single and double seal weld processes ensure integrity in the heat affected zone and provide long term solutions extending operation between turnarounds while maintaining integrity.
- ▶ gland packing system, that conforms to applicable international standards.
- ▶ the periphery of HF valve flanges, bonnet flanges included, are painted with VOC compliance HF-indicating paint.
- ▶ complete fire-safe design.
- ▶ special sizes available upon request.
- ▶ design which allows for simple, low-cost maintenance and extends life.
- ▶ extended life expectancy.



hf

## PRODUCT RANGE

**PETROLVALVES** HF valves product line covers the entire Gate, Globe and Check UOP range, as per classes and sizes required by UOP specifications. Each pipe class includes a wide range of valves, in order to cover all applications, like shown in below table.

UOP PIPE CLASS	GATE VALVES	GLOBE VALVES	CHECK VALVES
HF - 1	from 1/2" to 1", forged, 600# from 1"1/2 to 8", cast, 300#	from 1/2" to 1", forged, 600# from 1"1/2 to 8", cast, 300#	from 1/2" to 1", forged, lift check, 600# from 1"1/2 to 10", cast, swing check, 300#
HF - 10	not applicable	from 1/2" to 1", forged, 600# (sw + fl) from 1"1/2 to 8", cast, 300#	from 1/2" to 1", forged, lift check, 600# (sw + fl) from 1"1/2 to 10", cast, swing check, 300#
HF - 2 / HF - 20	from 1/2" to 1", forged, 800# (sw) from 1/2" to 1", forged, 600# from 1"1/2 to 24", cast, 300#	from 1/2" to 1", forged, 800# (sw) from 1/2" to 1", forged, 600# from 1"1/2 to 20", cast, 300#	from 1/2" to 1", forged, lift check, 800# (sw) from 1"1/2 to 24", cast, swing check, 300#
HF - 4 / HF - 40	from 1/2" to 1"1/2, forged, 800# (sw) from 2" to 24", cast, 150#	from 1/2" to 1"1/2, forged, 800# (sw) from 2" to 6", cast, 150#	from 1/2" to 1"1/2, forged, lift check, 800# (sw) from 2" to 16", cast, swing check, 150#
HF - 5 / HF - 50	from 1/2" to 1"1/2, forged, 800# (sw) from 2" to 24", cast, 300	from 1/2" to 1"1/2, forged, 800# (sw) from 2" to 6", cast, 300#	from 1/2" to 1"1/2, forged, lift check, 800# (sw) from 2" to 16", cast, swing check, 300#
HF - 6 / HF - 60	from 1/2" to 1"1/2, forged, 800# (sw) from 2" to 24", cast, 150#	from 1/2" to 1"1/2, forged, 800# (sw) from 2" to 6", cast, 150#	from 1/2" to 1"1/2, forged, lift check, 800# (sw) from 2" to 24", cast, swing check, 150#
HF - 7	from 1/2" to 1"1/2, forged, 800# (sw) from 2" to 24", cast, 300#	from 1/2" to 1"1/2, forged, 800# (sw) from 2" to 6", cast, 300#	from 1/2" to 1"1/2, forged, lift check, 800# (sw) from 2" to 24", cast, swing check, 300#

03

Valves with (SW) indications are available with Socket Weld ends, as per latest UOP specifications. All other valves are flanged.

## hf valves MATERIAL SELECTION

Material selection for alkylation purpose is determined by UOP specifications, starting from HF-1, the most critical class, to HF-7, the least critical one.

Table below shows HF valves materials according to UOP specs.

Where Monel trims are required, all trim parts are constructed in solid Monel materials and only K500 Monel stems are used for increased strength to minimize stem bending/twisting.

Combining Monel 400 seat rings with K500 solid forged Monel wedges eliminates the risk of galling between the critical sealing surfaces to ensure long-term sealing performance.

Carbon steel with monel overlay is never utilized as a base element in primary closure member components, such as the wedge or seat rings.

04

UOP PIPE CLASS	MATERIALS OF CONSTRUCTION	
	BODY/BONNET MATERIAL	TRIM MATERIAL
HF - 1	Monel	Monel
HF - 10	Monel	Monel
HF - 2 / HF - 20	Carbon steel	Monel
HF - 4 / HF - 40	Carbon steel	Monel
HF - 5 / HF - 50	Carbon steel	Monel
HF - 6 / HF - 60	Carbon steel	13% Cr (AISI 410)
HF - 7	Carbon steel	13% Cr (AISI 410)

## hf valves FEATURES

In order to improve valve functionality and extend valve life, in compliance with UOP applicable standard, **PETROLVALVES** HF product line includes several design improvements.

### threaded seat pocket WITH MONEL OVERLAY (CARBON STEEL VALVES)

**PETROLVALVES** developed a technique for the overlay of Monel 400 on Cast/Forged Carbon Steel valves (like shown on pictures below) of small sizes. Our procedures have proven over the long-term to eliminate any risk of HF Acid attacking and cutting through the heat affected zone, effectively extending operating cycles between turnarounds while maintaining high integrity isolation capability. Between Monel 400 overlay and carbon steel body, a Nickel butter layer is provided for separation, as per latest UOP specification requirements. This offers a high performance long-term solution for seat pocket corrosion, and guarantees the renewability of valve seats.

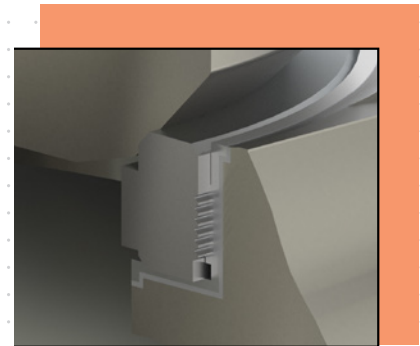

Globe

05

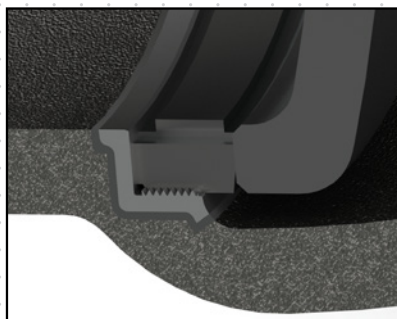

Swing

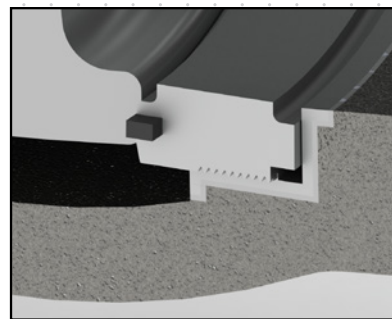

Gate

## double seal welded MONEL SEAT RING

**PETROLVALVES**, in compliance with UOP specifications, takes advantage of a double seal welding for Monel seat rings into Carbon Steel body pockets. This solution is proven over the long-term to completely eliminate any risk of HF Acid attack, thanks to the seal weld sealing effectiveness. This offers the best solution against seat pocket corrosion, because there is zero acid fluid leakage between the Monel seat ring and the carbon steel seat pocket.

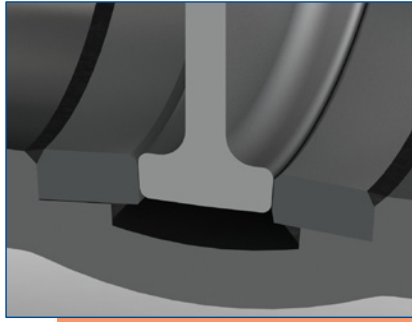

Gate

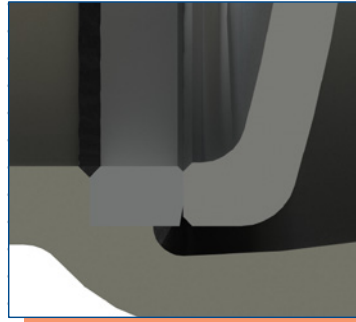

Swing



## PTFE insert (SOFT SEATS)

In case perfect sealing efficiency is required, PTFE inserts are available, where required by UOP specifications. The picture shows an example of a double seal welded Monel 400 seat ring facing with an integral Teflon insert on wedge.

As a primary seal, Teflon offers isolation integrity where bubble tight shut off is critical.

**PETROLVALVES** special construction guarantees metal back-up to the soft insert, therefore the valves are fire-safe. While the Teflon provides a dependable seal, the disc life is extended as its wear ratio is reduced considerably.

07

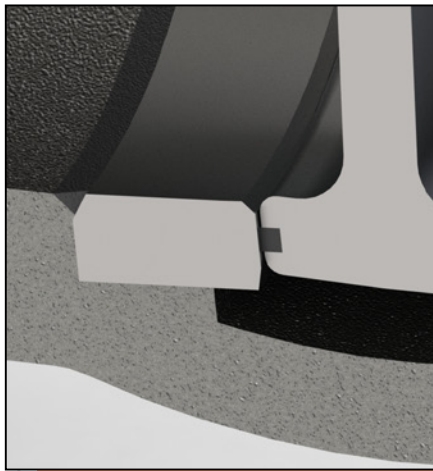

Gate

## sealant injectors FOR STEM AND SEATS (HF-1, HF-2)

**PETROLVALVES** uses the standardized construction shown below for all factory fitted grease injectors. For all applications where emergency sealant or HF resistant sealant injection is required, the double ball isolation system is employed for both packing gland and seat sealant applications (two examples shown on the right; globe on top, gate on bottom), where integrity must be assured. **PETROLVALVES** only recommends Polymel 410 for sealant/lubrication suitability in HF Alkylation service. The housing is Carbon Steel made for HF-2 valves and solid Monel for HF-1 valves, while all interiors are Monel made.

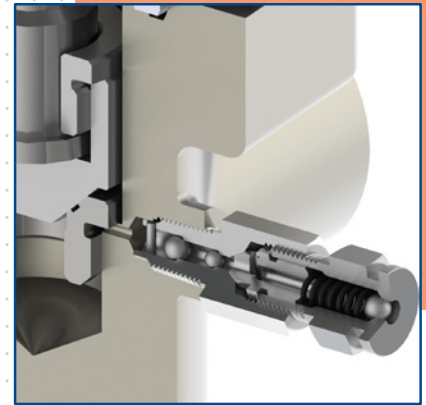

Globe

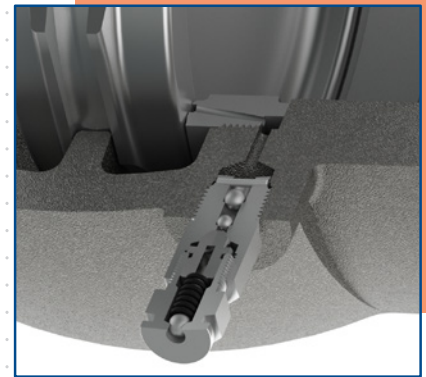

Gate

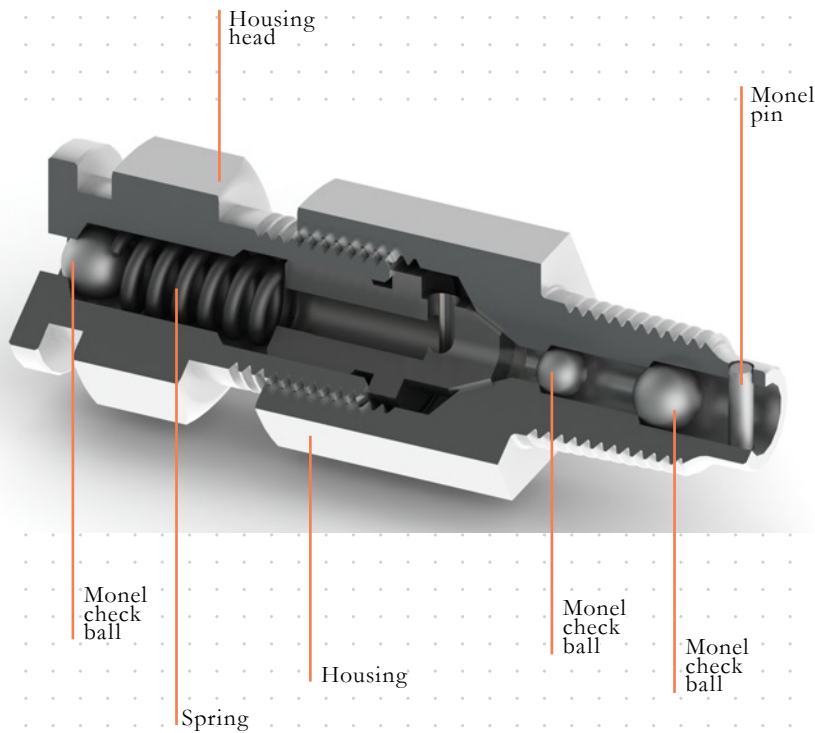

## HF valves TESTING

All HF valves are tested at each stage of production. Castings, forged bodies and bonnets, and wedge parts are exposed to RT, UT and visual testing procedures to verify pressure boundary integrity and to ensure that the items are suitable for production. Finished HF valves are shell tested with Kerosene. Extra Helium shell test is performed for castings. Further pressure testing is executed in-line according to API 598 standards using Kerosene and compressed air for all seat seal and shell tests.

## HF valves SERVICEABILITY

**PETROLVALVES** has designed all valve components to be renewable and to be readily available as spare parts. In addition, HF valves have been designed for easy disassembly and maintenance. Valve seats can be renewed while valve body remains in the pipeline (with threaded designs options only). Monel overlays in the seat pocket areas extend the life expectancy of the product while offering unequalled performance between turnarounds. Since the effect of corrosion is greatly reduced in the critical areas, standard replacement parts can be utilized during the life of the valve. **PETROLVALVES** offers complete HF valve the service and maintenance both on-site and at **PETROLVALVES** service facilities. Our scope of activities encompasses the service and reconditioning associated with minor and major shutdowns. Please contact **PETROLVALVES** after sales dept. to assist you in your service, maintenance or reconditioning needs. All work comes with a manufacture warranty and is consistent with technology licensor requirements.